



## THIGH & DRUMSTICK CUTTER



**foodmate**

Poultry Processing Systems

The Foodmate Thigh & Drumstick Cutter is a multi-purpose machine that can be used for both retail and food service applications. It has a simple construction design that contains no rebuild points, thus reducing the cost of ownership. It

provides an anatomic cut and depending on the type of cut, various configurations are possible. The electrical sync allows for more accurate cutting and the absence of a 90 degree gear box lowers maintenance costs.

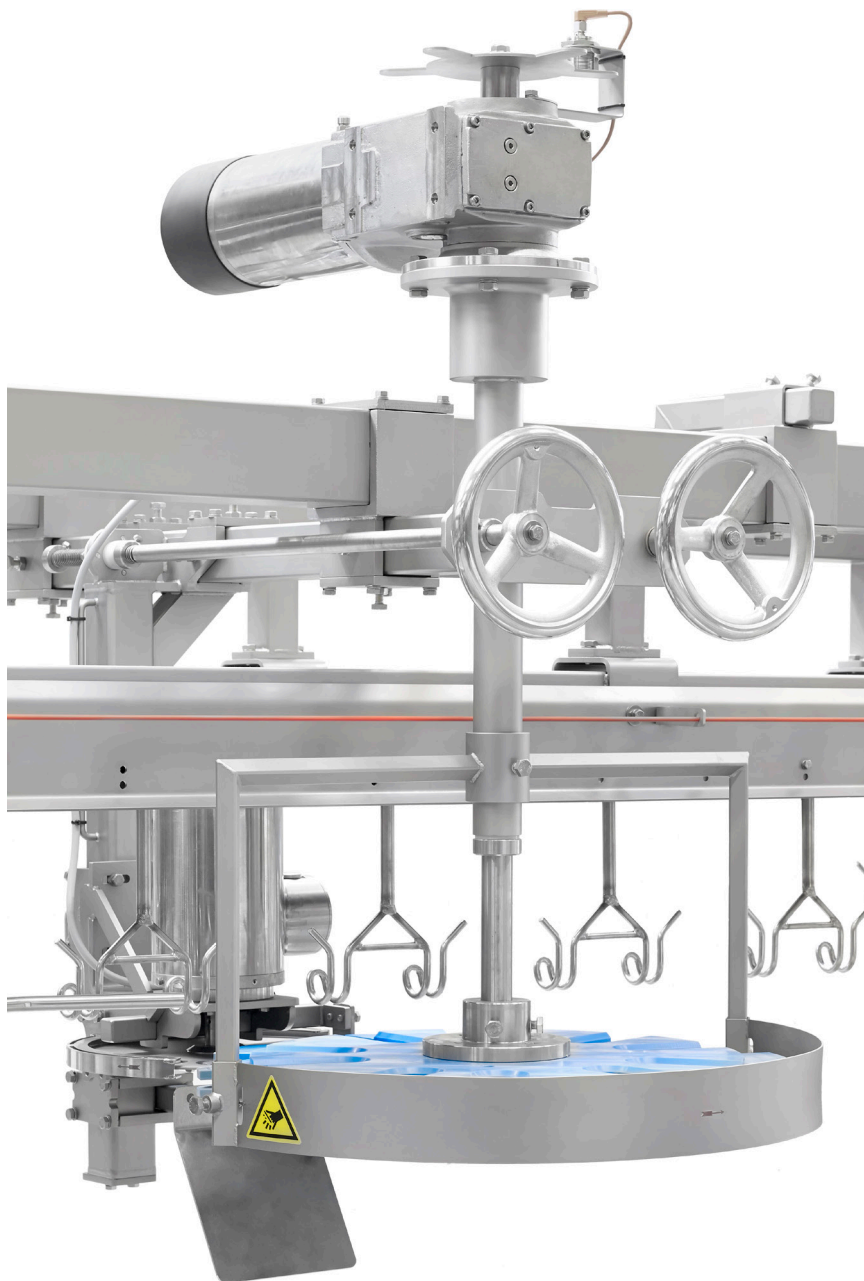

Our mission is to innovate, automate and bring cost-effective solutions to the industry.



# THIGH & DRUMSTICK CUTTER

## Key Benefits:

- Improves cut quality due to direct drive motor
- Increases line speed due to the direct drive gear box
- Allows for easy access to make adjustments
- Improves product appearance due to the direct drive motor
- Allows for a maximum of 6,000 birds per hour

Foodmate is an equipment manufacturing company based in the Netherlands. Founded in 2006, we focus primarily on poultry processing, and we recently launched Foodmate US, expanding our worldwide distribution into North America. Driven by research, paired with unmatched knowledge and decades of experience, it's our mission to innovate, automate and bring cost-effective solutions to the industry.

Our product line spans a wide assortment of processing equipment designed for live bird handling, killing and de-feathering, eviscerating, chilling, weighing, cut-up systems, deboning, and more. In addition to manufacturing, we provide an extensive variety of spare parts and service for other processing equipment and reconditioned machines.

Our team represents decades of industry knowledge and experience resulting in the engineering, development and implementation of new designs for our clients and their ever-changing needs.

## Technical Specifications:

- Stainless steel frame and motor
- Motor (IP66) power is 2 x 0,75 kW
- Machine dimensions:
  - Length: 1419 mm
  - Width: 802 mm
  - Height: 1345 mm
  - Weight: approx. 130 kg

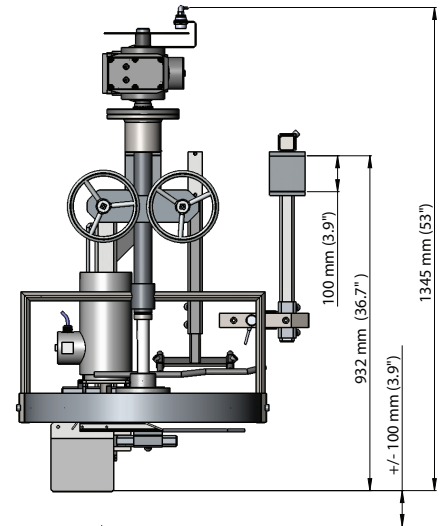
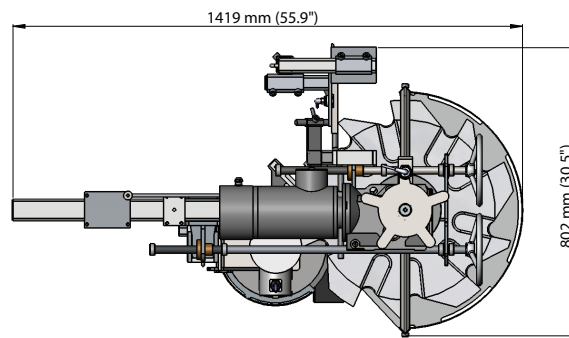

FOODMATE B.V.  
 Röntgenstraat 18 • 3261 LK Oud-Beijerland  
 P.O. Box 1405 • 3260 AK Oud-Beijerland  
 The Netherlands  
 Phone: +31-186 630240 • Fax: +31-186 630249  
 info@foodmate.nl  
 www.foodmate.nl

FOODMATE US, Inc.  
 300 Wilbanks Drive, Ball Ground, GA 30107  
 P.O. Box 4116, Canton, GA 30114  
 U.S.A.  
 Phone: +1-678-819-5270 (U.S.) • Fax: +1-678-819-5273  
 info@foodmateusa.com  
 www.foodmateus.com



# foodmate